

Photoelectric Sensor with Built-in Amplifier with New Connector Options

E3Z

Compact Sensor Offers Long Sensing Distance and Superior Noise-Immunity

- Photo-IC provides long sensing distance: 15 m and 10 m for through-beam, 4 m for retroreflective, and 1 m for diffuse.
- Integrated Photo-IC improves noise immunity to interference from inverters and other inductive loads.
- New injection molding technology assures IP67 rating to withstand water and dust.
- Switch-selectable, Light-ON/Dark-ON operation.
- M8 connector-ready and 2 m, pre-wired models.
- NPN or PNP output models available.



Ordering Information

■ Sensors

Stock Note: Shaded models are normally stocked.

Sensing method	Light source	Appearance	Connection method	Sensing distance	Model	
					NPN output	PNP output
Through-beam	IR/RED		Pre-wired	15 m (IR) 10 m (RED) (See Note 1.)	E3Z-T61(A)	E3Z-T81(A)
			Connector		E3Z-T66(A)	E3Z-T86(A)
			Pigtail 3 pin (M8)		E3Z-T61(A)-M5J	E3Z-T81(A)-M5J
			Pigtail 4 pin (M8)		E3Z-T61(A)-M3J	E3Z-T81(A)-M3J
			Pigtail 4 pin (M12)		E3Z-T61(A)-M1J	E3Z-T81(A)-M1J
Polarized retroreflective	RED	 (See Note 2.)	Pre-wired	100 mm to 4 m 100 mm to 3 m (See Note 3.)	E3Z-R61	E3Z-R81
			Connector		E3Z-R66	E3Z-R86
			Pigtail 3 pin (M8)		E3Z-R61-M5J	E3Z-R81-M5J
			Pigtail 4 pin (M8)		E3Z-R61-M3J	E3Z-R81-M3J
			Pigtail 4 pin (M12)		E3Z-R61-M1J	E3Z-R81-M1J
Diffuse reflective	IR		Pre-wired	5 to 100 mm (wide view)	E3Z-D61	E3Z-D81
			Connector		E3Z-D66	E3Z-D86
			Pigtail 3 pin (M8)		E3Z-D61-M5J	E3Z-D81-M5J
			Pigtail 4 pin (M8)		E3Z-D61-M3J	E3Z-D81-M3J
			Pigtail 4 pin (M12)		E3Z-D61-M1J	E3Z-D81-M1J
			Pre-wired	1 m	E3Z-D62	E3Z-D82
			Connector		E3Z-D67	E3Z-D87
			Pigtail 3 pin (M8)		E3Z-D62-M5J	E3Z-D82-M5J
			Pigtail 4 pin (M8)		E3Z-D62-M3J	E3Z-D82-M3J
			Pigtail 4 pin (M12)		E3Z-D62-M1J	E3Z-D82-M1J

- Note: 1. Model numbers that end with (A) are red LED versions.
 2. The Reflector is sold separately. Select the Reflector model most suited to the application.
 3. Sensing distance can be extended to 4 meters when the E39-R1S reflector is used. The sensing distance is 3 meters when the E39-R1 reflector is used.

■ **Accessories (order separately)**

Stock Note: Shaded models are normally stocked.

Slit for Through-beam Models (E3Z-T□□)

Order a slit for each emitter and receiver.

Slit width	Sensing distance (typical)	Minimum sensing object (typical)	Model
0.5 mm dia.	50 mm	0.5 mm dia.	E39-S65A
1 mm dia.	200 mm	1 mm dia.	E39-S65B
2 mm dia.	800 mm	2 mm dia.	E39-S65C
0.5 × 10 mm	1 m	0.7 mm dia.	E39-S65D
1 × 10 mm	2.2 m	1.2 mm dia.	E39-S65E
2 × 10 mm	5 m	2.4 mm dia.	E39-S65F

■ **Reflectors for Retroreflective Models**

Stock Note: Shaded models are normally stocked.

Name	Sensing distance (typical)	Model
Reflector	100 mm to 3 m	E39-R1
	100 mm to 4 m	E39-R1S
	100 mm to 5 m	E39-R2
	100 mm to 2.5 m	E39-R9
	100 mm to 3.5 m	E39-R10
Miniature Reflector	50 mm to 1.5 m	E39-R3
Tape Reflector	150 mm to 700 mm	E39-RS1
	150 mm to 1.1 m	E39-RS2
	150 mm to 1.4 m	E39-RS3

Note: The actual sensing distance may be reduced to approximately 70% of the typical sensing distance when using a Reflector other than the E39-R1 or the E39-R1S.

■ Mounting Brackets

Stock Note: Shaded models are normally stocked.

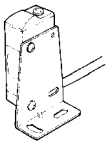
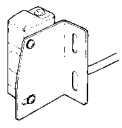
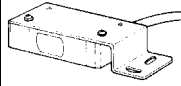
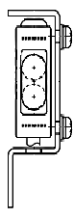
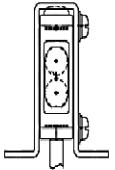
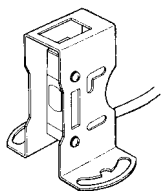
Appearance	Description	Model
	L-bracket, horizontal	E39-L104
	L-bracket, vertical	E39-L44
	Open top, 20° angle adjustability	E39-L43
	Protected top 5° angle adjustability	E39-L144
	Compact vertical protective cover bracket	E39-L142
	Vertical protective cover bracket	E39-L98

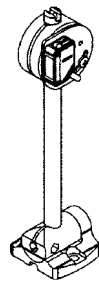
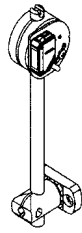
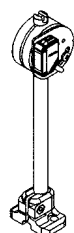
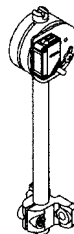
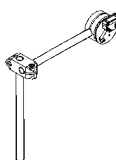
Appearance	Description	Model
	Adjustable height and angle bracket for sensors; horizontal mounting rotates every 45 degrees Mounted to the aluminum frame rails of conveyors, easily adjustable	E39-L93FH
	Adjustable height and angle bracket for sensors; vertical mounting rotates every 45 degrees	E39-L93FV
	Adjustable height and angle bracket for sensors; fixed horizontal base mounting	E39-L93H
	Adjustable height and angle bracket for sensors; fixed vertical base mounting	E39-L93V
	Adjustable height and angle bracket for sensors; free range of X and Y axis positioning; no base included for vertical post	E39-L93XY

Note: If a through-beam model is used, order two Mounting Brackets — one for the emitter and one for the receiver.

■ M8 CONNECTORS

Appearance	Cable type		Model
Straight	2 m (6.56 ft)	Four-wire type	XS3F-M421-402-A
	5 m (16.40 ft)		XS3F-M421-405-A
Right angle	2 m (6.56 ft)		XS3F-M422-402-A
	5 m (16.40 ft)		XS3F-M422-405-A
Straight	2 m (6.56 ft)	Three-wire type	Y96E-M833SD2
	5 m (16.40 ft)		Y96E-M833SD5
Right angle	2 m (6.56 ft)		Y96E-M833RD2
	5 m (16.40 ft)		Y96E-M833RD5

■ M12 CONNECTORS

Appearance	Cable type		Model
Straight	2 m (6.56 ft)	Four-wire type	Y96E-44SD2
	5 m (16.40 ft)		Y96E-44SD5
Right angle	2 m (6.56 ft)		Y96E-44RD2
	5 m (16.40 ft)		Y96E-44RD5

Specifications

Item	Sensing method		Through-beam	Polarized retroreflective	Diffuse reflective	
		NPN output		E3Z-T61/T66 (A) (Note 3)	E3Z-R61/R66	E3Z-D61/D66
	PNP output		E3Z-T81/T86 (A) (Note 3)	E3Z-R81/R86	E3Z-D81/D86	E3Z-D82/D87
Sensing distance			15 m 10 m (A) (Note 3)	100 mm (4 m Note 1) (when using E39-R1S) 100 mm (3 m Note 2) (when using E39-R1)	White paper (100 × 100 mm): 100 mm	White paper (300 × 300 mm): 1 m
Standard sensing object			Opaque: 12 mm (dia. min.)	Opaque: 75 mm (dia. min.)	---	
Hysteresis			---		20% max. of setting distance	
Directional angle			Both emitter and re- ceiver: 3 to 15°	2 to 10°	---	
Light source (wave length)			Infrared LED (870 nm)	Red LED (660 nm)	Infrared LED (860 nm)	
Power supply voltage			12 to 24 VDC ±10% including 10% (p-p) max. ripple			
Current consumption			Emitter: 15 mA Receiver: 20 mA	30 mA max.		
Control output			100 mA max. at 26.4 VDC, open collector output (residual voltage: 2 V max.) < 10 mA (residual voltage: 1 V max.) L-ON/D-ON, switch selectable			
Circuit protection			Load short-circuit, re- versed power supply protection, and output reverse protection	Reversed power supply connection, output short-circuit, and mutual interference protection, and output reverse protection		
Response time			1 ms max.			
Sensitivity adjustment			One-turn potentiometer			
Ambient illumination (receiver side)	Incandescent lamp		3,000 ℓ max.			
	Sunlight		10,000 ℓ max.			
Ambient temperature	Operating		-25°C to 55°C (-13°F to 131°F)			
	Storage		-40°C to 70°C (-40°F to 158°F) with no icing or condensation			
Ambient humidity	Operating		35% to 85%			
	Storage		35% to 95% with no condensation			
Insulation resistance			20 MΩ min. at 500 VDC			
Dielectric strength			1,000 VAC, 50/60 Hz for 1 min			
Vibration resistance			10 to 55 Hz, 1.5-mm double amplitude or 300 m/s ² for 2 hours each in X, Y, and Z axes			
Shock resistance	Destruction		500 m/s ² 3 times each in X, Y, and Z axes			
Enclosure rating			IP67 (IEC60529) 1200 PSI Washdown (NEMA ICS5, ANNEX F)			
Approvals			CE			
Connection method			2 m cable or M8 connector			
Indicator			Operation indicator (orange) Stability indicator (green) Emitter has power indicator (orange) only			
Weight (packed state)	Pre-wired cable (2 m)		Approx. 120 g (4.2 oz)	Approx. 65 g (2.3 oz)		
	Connector		Approx. 30 g (1.1 oz)	Approx. 20 g (0.7 oz)		
Material			Case: PBT (polybutylene terephthalate); Lens: Denatured polyallylate			
Accessories			Instruction manual (Order Reflector and Mounting Bracket separately.)			

- Note: 1. Sensing distance can be extended up to 4 meters when the E39-R1S reflector is used.
 2. Sensing distance can be extended up to 3 meters when the E39-R1 reflector is used.
 3. Sensing distance is 10 meters when using the (A) versions (visible red LED, 660 nm).

Dimensions

Unit: mm (inch)

Sensors

Through-beam (Pre-wired Models)

E3Z-T61
E3Z-T81

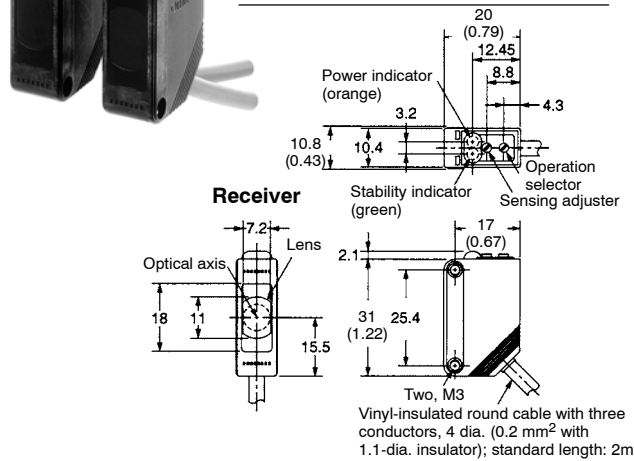
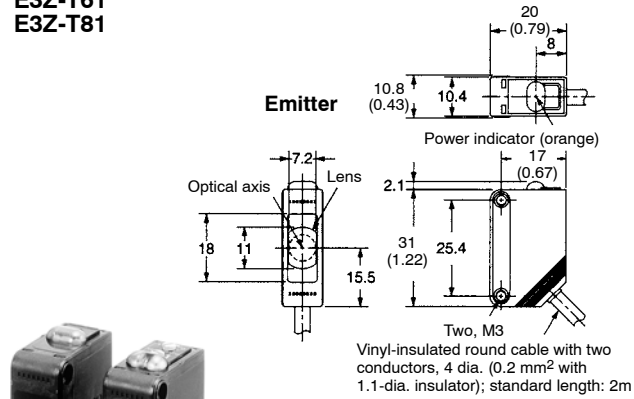

Through-beam (Connector Models)

E3Z-T66
E3Z-T86

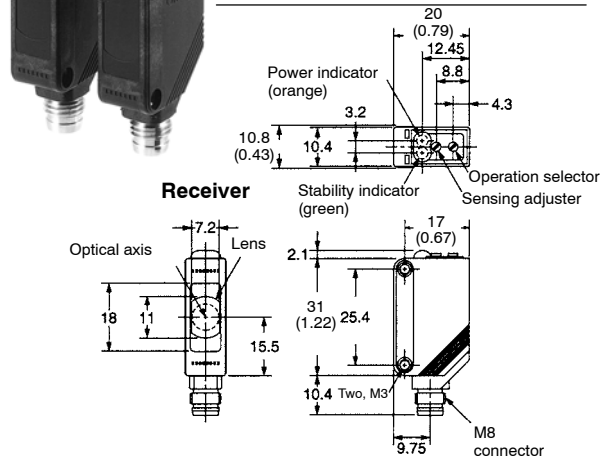
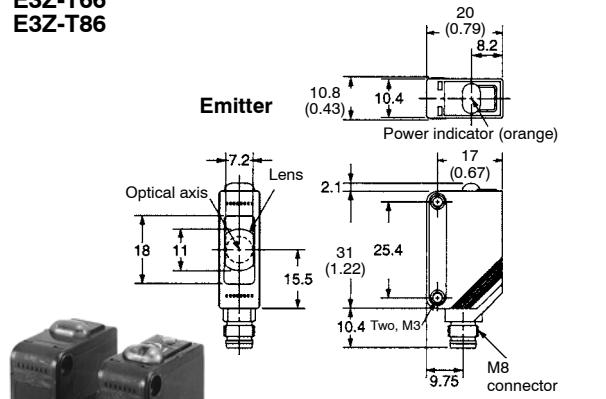

Retroreflective Models (Pre-wired Models)

E3Z-R61
E3Z-R81

Diffuse Reflective Models (Pre-wired Models)

E3Z-D61
E3Z-D62
E3Z-D81
E3Z-D82

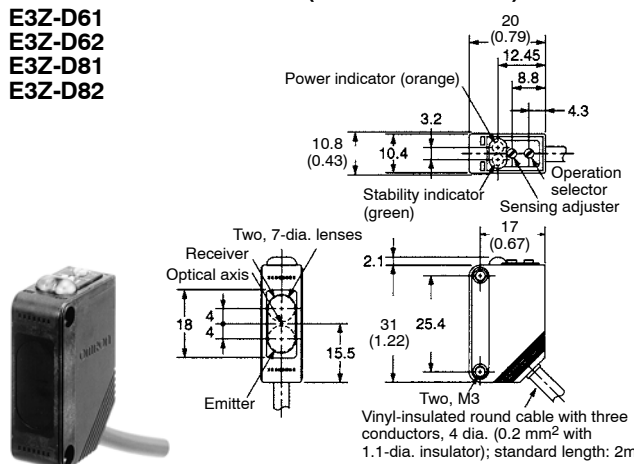

Retroreflective Models (Connector Models)

E3Z-R66
E3Z-R86

Diffuse Reflective Models (Connector Models)

E3Z-D66
E3Z-D67
E3Z-D86
E3Z-D87

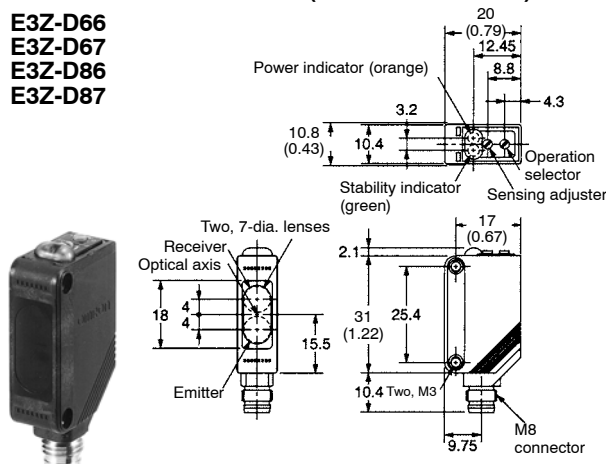

Note: Length of pigtailed: 0.3 m

Unit: mm (inch)

■ Slits

E39-S65A
E39-S65B
E39-S65C

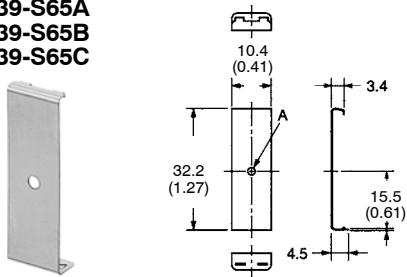

Model	Side A	Material
E39-S65A	0.5 dia.	SUS301 stainless steel
E39-S65B	1.0 dia.	
E39-S65C	2.0 dia.	

E39-S65D
E39-S65E
E39-S65F

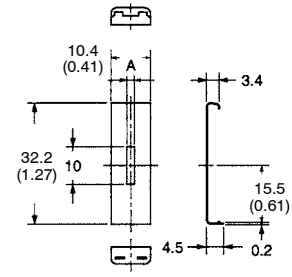

Model	Side A	Material
E39-S65D	0.5	SUS301 stainless steel
E39-S65E	1.0	
E39-S65F	2.0	

■ Reflectors

E39-R1
E39-R1S

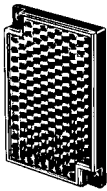

Material
Surface: Acrylic resin
Backside: ABS resin

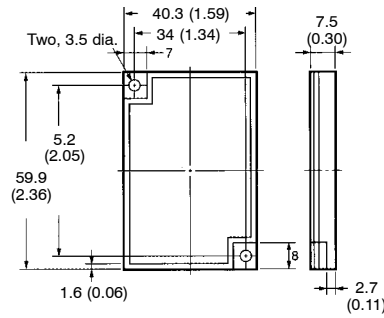

E39-R2

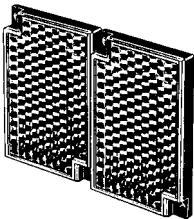

Material
Surface: Acrylic resin
Backside: ABS resin

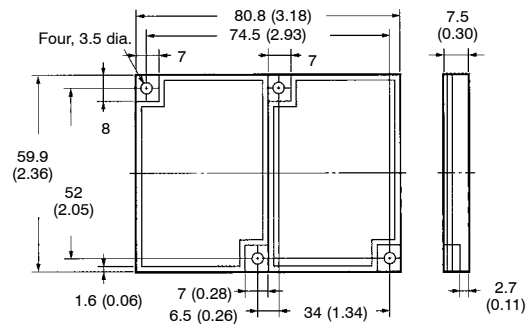

E39-R9



Material
Reflecting surface: Acrylic resin
Back: ABS resin

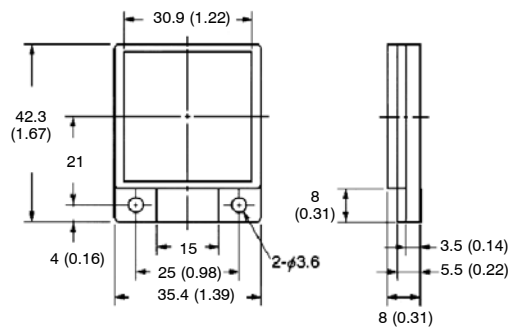

E39-R10

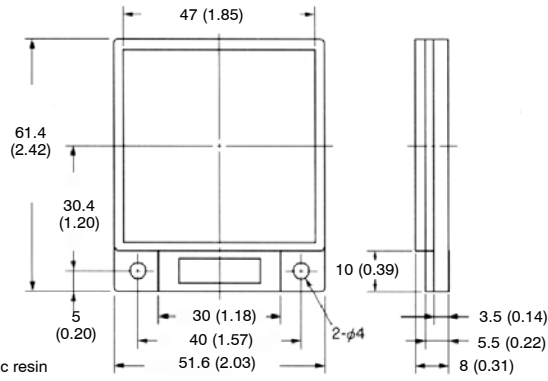

Material
 Reflecting surface: Acrylic resin
 Back: ABS resin

■ **Miniature Reflector**

E39-R3



Material
 Surface: Acrylic resin
 Backside: ABS resin

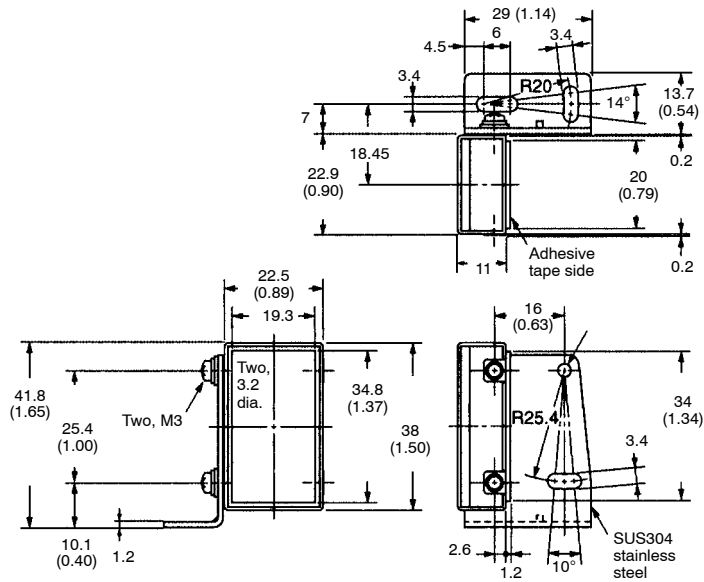

■ **Tape Reflectors**

E39-RS1

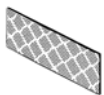

Material:
 Acrylic resin

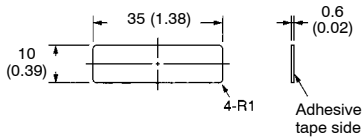

E39-RS3

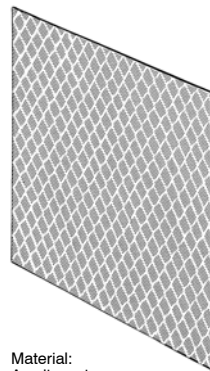

Material:
 Acrylic resin

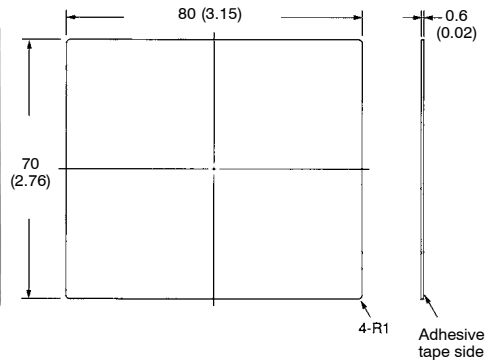

E39-RS2

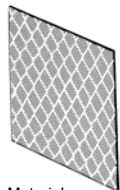

Material:
 Acrylic resin

